

# Model KBF-S 115 | Constant climate chambers with large temperature / humidity range

The Solid.Line KBF-S climate chamber is a custom-made solution for long-term testing and accelerated stability testing of pharmaceutical products in accordance with the ICH Q1A guideline. The corrosion-free and condensation-free interior also ensures exceptionally stable temperature and moisture levels, even when fully loaded.

## BENEFITS

- Homogeneous climate conditions thanks to APT.line™ preheating chamber
- Standard-compliant testing according to ICH Q1A
- Precise temperature and humidity control



Model 115

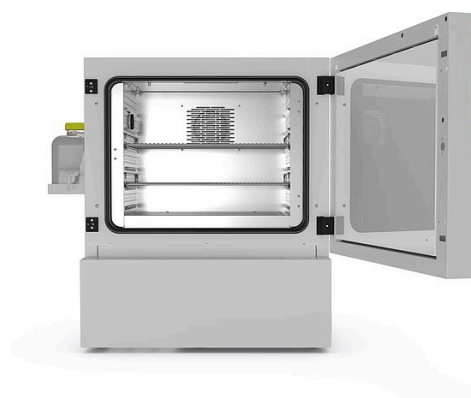

Model 115

## MAIN FEATURES

- Temperature range: 0 °C to +70 °C
- Humidity range: 20% to 80% RH
- APT.line™ preheating chamber technology
- Humidity regulation with capacitive humidity sensor and steam humidification
- LCD to display temperature and humidity along with additional information and alarms
- Internal data logger, measured values can be read out in open format via USB
- Unit self-test for comprehensive status analysis
- Inner chamber made completely of stainless steel
- 2 stainless steel racks, incl. shelf supports
- Access port with silicone plug, 30 mm, left
- Robust twin casters with brakes, from 240 L
- Class 3.1 independent temperature safety device (DIN 12880) with visual and audible temperature alarm
- Computer interface: Ethernet
- Independent water supply via tank

## ORDERING INFORMATION

Interior volume [L]	Voltage	Option model	Version	Art.-No.
102	200...230 V 1~ ph 50/60 Hz	Standard	KBFS115-230V	9020-0370
	200...240 V 1~ ph 50/60 Hz	Standard	KBFS115UL-240V	9020-0371

## TECHNICAL DATA

Description	KBFS115-230V <sup>1</sup>	KBFS115UL-240V <sup>1</sup>
<b>Article Number</b>	<b>9020-0370</b>	<b>9020-0371</b>
<b>Performance Data Temperature</b>		
Temperature range (max. 24 °C unter Umgebungstemperatur) [°C]	0...70	0...70
Temperature variation at 40 °C [± K]	0.3	0.3
Max. heat compensation at 40 °C [W]	200	200
<b>Performance Data Climate</b>		
Temperature range (max. 24 °C unter Umgebungstemperatur) [°C]	10...70	10...70
Temperature variation at 25 °C and 60 % RH [± K]	0.3	0.3
Temperature variation at 40 °C and 75 % RH [± K]	0.3	0.3
Temperature fluctuation at 25 °C and 60 % RH [± K]	0.1	0.1
Temperature fluctuation at 40 °C and 75 % RH [± K]	0.1	0.1
Humidity range [% RH]	20...80	20...80
Humidity fluctuation at 25 °C and 60 % RH	2,0 % RH	2,0 % RH
Humidity fluctuation at 40 °C and 75 % RH	2,0 % RH	2,0 % RH
Recovery time after 30 seconds door open at 25 °C and 60 % RH [min]	6	6
Recovery time after 30 seconds door open at 40 °C and 75 % RH [min]	7	7
<b>Electrical data</b>		
Rated Voltage [V]	200...230	200...240
Power frequency [Hz]	50/60	50/60
Nominal power [kW]	1.4	1.4
Unit fuse [A]	16	16
Phase (Nominal voltage)	1~	1~
<b>Measures</b>		
Interior volume [L]	102	102
Net weight of the unit (empty) [kg]	128	128
Permitted load [kg]	100	100
Load per rack [kg]	30	30
Wall clearance back [mm]	100	100
Wall clearance sidewise [mm]	100	100
<b>Internal Dimensions</b>		
Width [mm]	600	600
Height [mm]	483	483
Depth [mm]	351	351
<b>Doors</b>		
Unit doors	1	1
<b>Housing dimensions not incl. fittings and connections</b>		
Width net [mm]	880	880
Height net [mm]	1050	1050
Depth net [mm]	650	650
<b>Environment-specific data</b>		
Energy consumption at 40 °C and 75 % RH [Wh/h]	400	400
Sound-pressure level [dB(A)]	52	52
<b>Fixtures</b>		
Number of shelves (std./max.)	2/5	2/5

1 All technical data is specified for unloaded units with standard equipment at an ambient temperature of +22 °C ±3 °C and a power supply voltage fluctuation of ±10 %. The temperature data is determined in accordance to BINDER factory standard following DIN 12880, observing the recommended wall clearances of 10 % of the height, width, and depth of the inner chamber. Technical data refers to 100 % fan speed. All indications are average values, typical for units produced in series. We reserve the right to change technical specifications at any time.

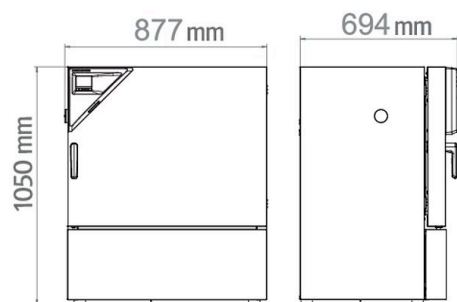
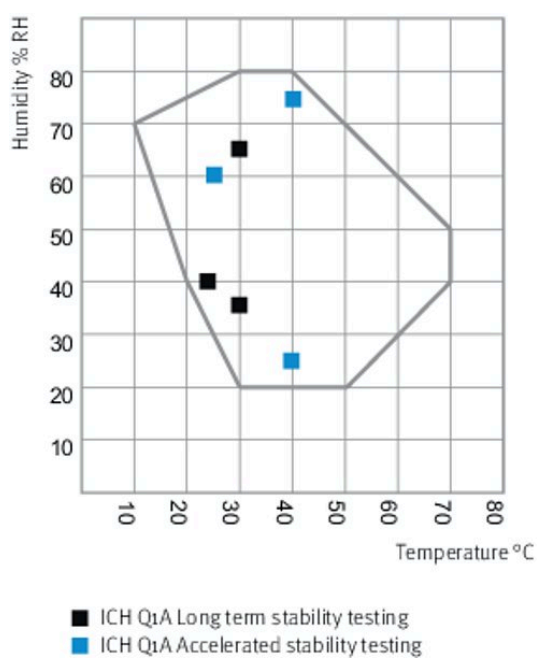
**DIMENSIONS incl. fittings and connections [mm]**

**CHARTS**

Climate chart

**OPTIONS**

Designation	Description	*	Art.-No.
	left		
	30 mm	01	8012-1442
	50 mm	01	8012-1472
	100 mm	01	8012-0515
	right		
<b>Access port with silicone plug</b>	30 mm	01	8012-1436
	50 mm	01	8012-1466
	100 mm	01	8012-0514
	top		
	30 mm	01	8012-1448
	50 mm	01	8012-1454
	100 mm	01	8012-1460
<b>Calibration certificate, expanded</b>	for temperature and humidity; for extending the measurement in center of chamber to include another test value	-	8012-0155

\* Notes › See last page

Designation	Description	*	Art.-No.
<b>Calibration certificate, temperature</b>	temperature measurement incl. certificate and 27 measuring points at specified temperature	-	8012-0923
	temperature measurement incl. certificate, 15- 18 measuring points at specified temperature	-	8012-0920
	temperature measurement incl. certificate, 9 measuring points at specified temperature	-	8012-0917
<b>Calibration certificate, temperature and humidity</b>	Measurement in center of chamber at 25 °C / 60% RH or at specified test values	-	8012-0154
	temperature (according to DIN12880) and humidity measurement incl. certificate, 27 temperature measuring points and 1 humidity measuring point, at 25 °C / 60 % RH or at specified values	-	8012-0924
<b>Door lock</b>	lockable door handle	-	8012-1978

\* Notes › See last page

## ACCESSORIES

Designation	Description	*	Art.-No.
<b>APT-COM™ 4 BASIC-Edition</b>	for simple logging and documentation requirements with up to 5 networked units. version 4, BASIC edition	-	9053-0039
<b>APT-COM™ 4 GLP-Edition</b>	for working under GLP-compliant conditions. Measured values are documented in a tamper-proof way in line with the requirements of FDA Regulation 21 CFR 11. version 4, GLP edition	-	9053-0042
<b>APT-COM™ 4 PROFESSIONAL-Edition</b>	convenient unit and user management built on the BASIC edition. Suitable for networking up to 100 units. version 4, PROFESSIONAL edition	-	9053-0040
<b>BINDER PURE AQUA SERVICE</b>	System for preparation or complete desalination of tap water, complete set containing PURE AQUA 300 single-use cartridge, measuring device, and all necessary connecting parts	-	8012-0759
<b>BINDER PURE AQUA SERVICE, accessories</b>	Single-use, replacement cartridge for BINDER PURE AQUA System	-	6011-0165
<b>Convenient water supply</b>	Flexible positioning of the water container with magnetic holder, hose adapter for water container with practical quick coupling, and water stop function		
	External, with magnetic holder	-	8012-1847
<b>Data Logger Kit</b>	T 220: For continuous temperature logging from -90 °C to 220 °C. The kit includes 1 data logger, Pt 100 sensor with 2 m extension cable and 1 magnetic fixture for mounting to the BINDER unit	-	8012-0715
	TH 70/70: For continuous temperature and humidity logging from -40 °C to 70 °C / 0% to 100% RH and additional logging of ambient conditions. Kit includes 1 data logger, 2 attachable combined humidity/temperature sensors, 2 m extension cable and 1 fixture for mounting to the BINDER unit	-	8012-0717
	TH 70: For continuous temperature and humidity logging from -40 °C to 70 °C; 0% to 100% RH. Kit includes 1 data logger, Pt 100 sensor with 2 m extension cable, and 1 magnetic fixture for mounting to the BINDER unit	-	8012-0716
<b>Data Logger Software</b>	LOG ANALYZE software kit, configuration and evaluation software for all BINDER Data Logger Kits (incl. USB data cable)	-	8012-0821
<b>LED light bars</b>	Basic set consisting of 2 pieces, attachment material, control unit for max. 4 light strips, 100-240 V, 50/60 Hz		
	Basic set 300, length 30 cm	-	8012-1107
	Basic set 500, length 50 cm	-	8012-1108
	Expansion set consisting of 2 pieces, attachment material: clips. For expanding the basic set of light bars		
	Expansion set 300, length 30 cm	-	8012-1716
	Expansion set 500, length 50 cm	-	8012-1717
<b>pH-neutral detergent</b>	concentrated, for gentle remove of residual contaminants; 1 kg	-	1002-0016
<b>Qualification documents</b>	IQ/OQ documents – supporting documents for validation performed by customers, consisting of: IQ/OQ checklists incl. calibration guide and comprehensive unit documentation; parameters: temperature and humidity values		
	Digital in PDF format	-	7057-0002
	Hard copy inside folder	-	7007-0002
	IQ/OQ/PQ documents – supporting documents for validation performed by customers, according to customer requirements, PQ section added to qualification folder IQ/OQ; parameters: temperature and humidity values		
	Digital in PDF format	-	7057-0006
	Hard copy inside folder	-	7007-0006
<b>Rack</b>	stainless steel	-	6004-0112

\* Notes › See last page

Designation	Description	*	Art.-No.
<b>Rack accessories</b>	fasteners (1 set of 4) for additional security of racks	-	8012-0620
<b>Rack, reinforced</b>	stainless steel, with fasteners (1 set of 4)	-	8012-0700
<b>Shelf, perforated</b>	Stainless steel	-	6004-0115
<b>WLAN kit</b>	The kit contains a client bridge that establishes a wireless connection between BINDER units and APT-COM4, LIMS, or customer-specific software via an Ethernet interface. It provides an alternative solution in situations where units need to be positioned in locations without an on-site Ethernet connection. In secured networks, installation and configuration must be performed by the customer's IT service.	-	8500-0164

\* Notes › See last page

## SERVICES

Designation	Description	*	Art.-No.
<b>Installation services</b>			
Unit commissioning	Connect the unit to the customer-side connections (electricity, water, wastewater, gas), basic functions check, brief operating instructions. (excl.: unpacking, setup, controller instructions, programming, installation work)	05	DL10-0300
Unit instructions	Instruction regarding operating principle and basic functions of the unit, operation of the control electronics including programming	05	DL10-0700
<b>Maintenance contracts</b>			
<b>Maintenance services</b>			
BRONZE 3-year maintenance contract	Maintenance service as contractually agreed, visual inspection of mechanical and electrical components, check of control response, 20% discount on spare parts	05	DL20-0710
GOLD 3-year maintenance contract	Maintenance service as contractually agreed, visual inspection of mechanical and electrical components, check of control response, 20% discount on spare parts, testing of all key functions, replacement of wear parts, calibration of one temperature/humidity value, including certificate	05	DL20-0920
Maintenance	One-off maintenance service in accordance with maintenance schedule. Visual inspection of mechanical and electrical components, testing of all key functions. Calibration of a test temperature specified by the user in center of usable space without certificate	05	DL20-0400
SILVER 3-year maintenance contract	Maintenance service as contractually agreed, visual inspection of mechanical and electrical components, check of control response, 20% discount on spare parts, testing of all key functions, calibration of one test temperature specified by the user in the center of the usable space, without certificate	05	DL20-0820
<b>Calibration services</b>			
Temperature and humidity calibration	Expansion –Temperature and humidity calibration with 1 measuring point in center of chamber with 1 specified pair of values, including certificate	03, 04, 05	DL30-0302
	Temperature and humidity calibration with 1 measuring point in center of chamber with 1 specified pair of values, including certificate	03, 04, 05	DL30-0301
Temperature and humidity measurement according to DIN12880	Temperature measurement in accordance with DIN 12880 with 27 temperature measuring points and 1 humidity measuring point in center of chamber with a pair of values specified by the user, including certificate	03, 04, 05	DL30-0427
Temperature and humidity measurement, 18-1 measuring points	Temperature measurement with 18 temperature measuring points and 1 humidity measuring point in center of chamber with a pair of values specified by the user, including certificate	03, 04, 05	DL30-0318
Temperature and humidity measurement, 27-1 measuring points	Temperature measurement with 27 temperature measuring points and 1 humidity measuring point in center of chamber with a pair of values specified by the user, including certificate	03, 04, 05	DL30-0327
Temperature and humidity measurement, 9-1 measuring points	Temperature measurement with 9 temperature measuring points and 1 humidity measuring point in center of chamber with a pair of values specified by the user, including certificate	03, 04, 05	DL30-0309
<b>Validation services</b>			
Execution of IQ/OQ	Execution of IQ/OQ in accordance with qualification folder	05	DL42-0300
Execution of IQ/OQ/PQ	Execution of IQ/OQ/PQ in accordance with qualification folder	05	DL44-0500
<b>Warranty service</b>			
1-year warranty extension	The warranty is extended by 1 year from the delivery date, wear parts are excluded	-	DL50-0030

\* Notes › See last page

## NOTES

- 01 Condensation may occur in the area around the access port. Access ports may be placed in custom locations for an additional charge.
- 02 UL mark is not granted when this option is used.
- 03 Sensor calibration is performed in an accredited calibration laboratory.
- 04 Calibration is performed according to the BINDER factory standard.
- 05 Quoted prices do not include travel costs. Please refer to the chapter on BINDER Service for travel costs for your region. Quoted prices for services performed in Switzerland do not include a country-specific added fee (available on request).

### **BINDER GmbH**

Tuttlingen, Germany  
TEL +49 7462 2005 0  
FAX +49 7462 2005 100  
info@binder-world.com  
www.binder-world.com

### **BINDER Asia Pacific (Hong Kong) Ltd.**

Kowloon, Hong Kong, P.R. China  
TEL +852 39070500  
FAX +852 39070507  
asia@binder-world.com  
www.binder-world.com

### **Representative Office for CIS**

Moscow, Russia  
TEL +7 495 988 15 16  
FAX +7 495 988 15 17  
russia@binder-world.com  
www.binder-world.com

### **BINDER Environmental Testing Equipment (Shanghai) Co., Ltd.**

Shanghai, P.R. China  
TEL +86 21 685 808 25  
FAX +86 21 685 808 29  
china@binder-world.com  
www.binder-world.com

### **BINDER Inc.**

Bohemia, NY, USA  
TEL +1 631 224 4340  
FAX +1 631 224 4354  
usa@binder-world.com  
www.binder-world.us